

<b>Category</b>	Battens and Weatherproofs
<b>Application</b>	Ancillary, Commercial, Education, Healthcare, Hospitality, Industrial, Retail
<b>Specification</b>	Performance

# Tornado PRO

Tornado PRO Twin 1500mm  
Code: ATORPLED2X5

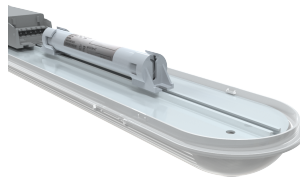

- Ultra slim IP65 LED robust non-corrosive batten ideal for industrial applications and ancillary areas
- Unique base design caters for multiple installation methods
- Quick release LED array / gear tray assembly provides the installer the means to faster installation / maintenance
- Self-test emergency option with Li-ion battery technology, reducing charge time and running costs

- High efficiency up to 161 Lm/W
- Installer friendly embedded features aid accurate and fast installation for any application
- Fast latching / permanently located stainless steel side clips ensure a quick and secure connection
- High output 5ft options available

## GENERAL INFORMATION

<b>Wattage</b>	61W
<b>Lumens Delivered</b>	6300lm
<b>Lm/W</b>	103lm/W
<b>Beam Angle</b>	100/120
<b>CRI</b>	80
<b>CCT</b>	4000K
<b>Input</b>	220-240V
<b>Operating Temp</b>	-10°C - 40°C
<b>SDCM</b>	3
<b>Product Weight without Packaging</b>	2.226 kg

## TECHNICAL INFORMATION

<b>Light Source</b>	LED
<b>Colour / Finish</b>	Grey
<b>IP Rating</b>	IP65
<b>Class Protection</b>	1
<b>Internal / External</b>	Internal / External
<b>Surface / Recessed / Suspended</b>	Ceiling, Suspended
<b>Lumen Depreciation</b>	L80 54,000h
<b>Warranty (Years)</b>	7
<b>CE Mark</b>	Yes
<b>Height</b>	70 mm
<b>Accessories</b>	ATORPLED/SSKIT/SINGLE, ATORPLED/SSKIT/TWIN

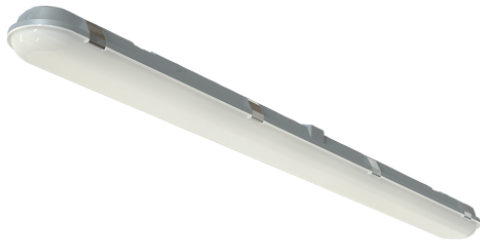

<b>Category</b>	Battens and Weatherproofs
<b>Application</b>	Ancillary, Commercial, Education, Healthcare, Hospitality, Industrial, Retail
<b>Specification</b>	Performance

# Tornado PRO

Tornado PRO Twin 1500mm

**Code:** ATORPLED2X5

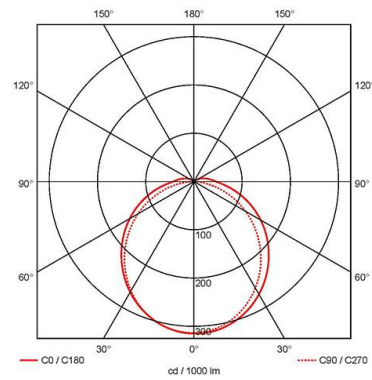
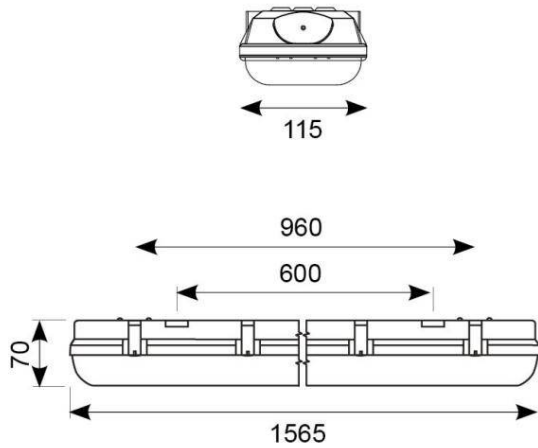

## ACCESSORIES

ATORPLED/SSKIT/SINGLE	Tornado PRO 316L Stainless Steel Kit Single
ATORPLED/SSKIT/TWIN	Tornado PRO 316L Stainless Steel Kit Twin